

A broad and
sustainable vision for

**OUTDOOR
STREET FURNITURE**

**GOVA[®] street
PLAST**

Index

Our story, your future	4
Values	6
An everlasting vision	7
23 reasons	8
Our mission	10
Design	12
Pure	36
Comfort	46
Traffic	68

“

ONCE IS NOT ENOUGH
the importance of recycling.

Recycling waste today is still a choice.
Tomorrow it will be a necessity.

For several years now, Govaplast has been proving that a durable
solution for the growing plastic waste stream does exist.

With continuous growth for more than 50 years, global world
plastics production has risen from 1.7 million tonnes in 1950,
to 288 million tonnes in 2012. This is a striking figure...

European production alone accounts for about 57 million tonnes
of this total amount.

25 million tonnes of plastics ended up in the waste stream in 2012
of which 6.6 million tonnes were used in recycling.

We are pleased to take part in this cycle, with durable and
recyclable products as a result.

”

Govaerts Recycling Team

Our story, your future

since 1995

We started our production in 1995 from scratch with no experience at all in the recycling sector.

But we learned fast and expanded fast from a single production unit into an extended machinery park. We could easily say that innovative ideas and a lot of guts brought us where we are standing now, being the market leader in the production of sustainable products in recycled plastic.

NL: Ons verhaal, uw toekomst

Bij de oprichting van Govaerts Recycling nv in 1995 hadden we helemaal geen ervaring in de recyclingsector. We leerden echter snel waardoor onze productie-eenheid al gauw uitgroeide tot een groot machinepark. Dankzij een mix van voortdurende vernieuwing en flink wat lef, zijn we vandaag marktleider in de productie van duurzame producten in gerecycled plastic.

FR: Notre histoire, votre futur

Partis d'une feuille blanche en 1995, sans aucune expérience du secteur du recyclage, nous sommes devenus leader du marché pour la fabrication de produits en plastique recyclé. Nous avons vite appris et nous sommes rapidement passés d'une seule unité de production à un parc étendu de machines. Quelques idées innovantes et un peu d'audace nous ont conduits là où nous sommes aujourd'hui, soit leader du secteur.

DE: Unsere Geschichte, Ihre Zukunft

1995 begannen wir unsere Produktion von Null und ohne jedwede Erfahrung im Recyclingsektor. Aber wir haben schnell gelernt und konnten uns rasch von einer einzelnen Produktionseinheit zu einem umfassenden Maschinenpark vergrößern. Innovative Ideen und viel Mut haben uns dahin gebracht, wo wir heute stehen: Marktführer bei der Produktion nachhaltiger Produkte aus recyceltem Kunststoff.

Values

Innovation

Govaerts Recycling always aims to be at the forefront of innovation when it comes to product development, design and manufacturing processes. We are constantly looking to meet our customer's needs and to adapt our products to the latest requirements.

Quality

Our products have been tested by independent specialists, with good results, emphasizing the importance to supply top quality. This is translated into a 10 year guarantee on the material.

NL: Innovatie

Govaplast wil een voortrekkersrol spelen op het vlak van innovatie. Wij ontwikkelen vernieuwende producten met een eigentijds design volgens de allernieuwste productieprocessen. Daarbij staan de veranderende wensen en behoeften van onze klanten steeds centraal.

Kwaliteit

Onze producten zijn stuk voor stuk getest door onafhankelijke vakspecialisten. De goede resultaten beklemtonen ons voortdurende streven naar hoogstaande kwaliteit. We hebben vertrouwen in onze producten. Daarom ook bieden we altijd tien jaar garantie op ons materiaal.

FR: Innovation

Govaplast désire toujours être à la pointe de l'innovation en matière de développement de produits, de design et de processus de fabrication. Nous cherchons en permanence à satisfaire vos besoins à adapter nos produits aux nouvelles exigences.

Qualité

Nous avons confié les tests de nos produits aux meilleurs spécialistes indépendants dans le souci d'une amélioration permanente de la qualité. Ces tests nous permettent de vous accorder une garantie de 10 ans sur le matériel.

DE: Innovation

Govaplast strebt danach, Innovationsführer bei Produktentwicklung, Design und Herstellungsprozessen zu sein. Wir wollen die Bedürfnisse unser Kunden immer erfüllen und passen unsere Produkte den Wünschen und Bedürfnissen an.

Qualität

Unsere Produkte wurden von unabhängigen Spezialisten mit guten Ergebnissen geprüft. Dabei zeigt sich wieder einmal, wie wichtig es ist, Spitzenqualität zu liefern. Dieses findet sich wieder in der Garantie von 10 Jahren auf das Material.

An everlasting vision

Cradle to cradle

The protection of the environment has always been our focal point.

Govaplast wishes to play an active role in the entire recycling process, thus contributing to the protection of our eco system.

Our production process is a perfect example of the cradle-to-cradle philosophy: we use recycled material and our end products are 100% recyclable again. We use 'green' power and re-use our cooling-water, reducing our ecological footprint.

A sophisticated production process and the use of high-grade raw materials enables us to produce and supply high-quality products. The raw material consists of 100% plastic recycled material (PE and PP).

NL: Cradle to cradle

Govaplast wil van a tot z een actieve rol spelen in het recyclingproces, en op die manier bijdragen aan het behoud van ons ecosysteem.

Ons productieproces is een schoolvoorbeeld van de cradle-to-cradle-filosofie die wij hanteren. We gebruiken niet alleen gerecyclede materialen, ook onze eindproducten zijn opnieuw 100% recyclebaar. We gebruiken groene energie en hergebruiken ons koelwater om zo onze ecologische voetafdruk te verkleinen.

Dankzij ons geavanceerde productieproces en het gebruik van hoogwaardige grondstoffen kunnen wij producten van topkwaliteit maken en leveren. Onze grondstoffen bestaan voor 100% uit gerecycled plastic (PE en PP).

FR: Cradle to cradle

La protection de l'environnement est depuis toujours notre préoccupation principale. Govaplast a un rôle actif dans l'ensemble du processus de recyclage et l'entreprise contribue à la protection de notre planète. Pour y arriver, nous suivons la philosophie cradle to cradle, nous utilisons de la matière recyclée et nos produits finis sont, à leur tour, recyclables à 100 %.

Notre usine consomme de l'énergie « verte » et utilise l'eau de refroidissement en circuit fermé, réduisant ainsi notre empreinte écologique.

Le processus original de production et l'utilisation de matières premières d'excellente qualité fournissent des produits haut de gamme à base de 100 % de matières plastiques recyclées (PE et PP).

DE: Cradle to cradle

Der Schutz der Umwelt lag uns schon immer am Herzen. Govaplast will im gesamten Recyclingprozess eine aktive Rolle spielen und so zum Schutz unseres Ökosystems beitragen.

Unser Produktionsprozess ist ein perfektes Beispiel für die Cradle-to-Cradle-Philosophie: Wir verwenden recyceltes Material und unsere Endprodukte selbst sind auch wieder 100% recycelbar. Wir verwenden „grünen“ Strom und auch unser Kühlwasser wird wiederverwendet. So reduzieren wir unseren ökologischen Fußabdruck.

Ein anspruchsvoller Produktionsprozess und die Verwendung von hochwertigen Rohstoffen erlauben uns, qualitativ hochwertige Produkte herzustellen und zu liefern. Die Rohstoffe bestehen zu 100% aus recyceltem Kunststoffmaterial (PE und PP).



All advantages at a glance

23 REASONS
why we think this is a
WONDERFUL PRODUCT



Impact resistant



Solid core



Non slip material



Natural texture



8 colours



10 year warranty on our profiles



Easy to work



Sunlight (UV) resistant



Maintenance free



Coloured throughout



Systematically tested



Flexible



Splinter-free



Completely recyclable



Everlasting



Consistently engineered



Many different profiles



Rot-proof



Non absorbing



100% plastic waste



Graffiti resistant



Easy scratch removal



Weatherproof

There's around 25 million tons of waste in Europe. 10 million tons of this amount is pure plastic disposal, 8,7 million tons can be recovered for energy and only 6 million tons is being recycled today.

“ Our mission is to contribute
TO MAKE THIS BETTER



100%
RECYCABLE
products



315 million
RECYCLED
**PLASTIC
BOTTLES**
used last year



14 400 km
PROFILES
produced
IN 1 YEAR



**PP - LDPE
& HDPE**
makes our
IDEAL MIX



**DEALER
NETWORK**
23 over
COUNTRIES



**AWARD
WINNING**
products



NON production
STOP
24/7



every **m²** **DECKING**
CONTAINS
920 **PLASTIC**
bags **SHOPPING**

We make the
SWITCH FROM WASTE TO QUALITY products.
Let us inspire you to
MAKE THIS SWITCH OF MINDSET too ”



“Where **PRACTICALITY**
meets **BEAUTY**”

1.

DESIGN collection

The Govaplast Design range has been created to meet the requirements for a contemporary feel in modern city architecture.

NL: De Govaplast Design-collectie is speciaal ontworpen om moderne steden een eigentijdse look te geven.

FR: La gamme Govaplast Design répond aux exigences du style contemporain dans une architecture urbaine moderne.

DE: Die Govaplast Designpalette erfüllt alle Anforderungen für eine zeitgemäße Ausstrahlung in einer modernen Stadtarchitektur.



MINIMALISM
in its pure and simple lines

MATRIX benches & table

collection of matching SEATING ELEMENTS

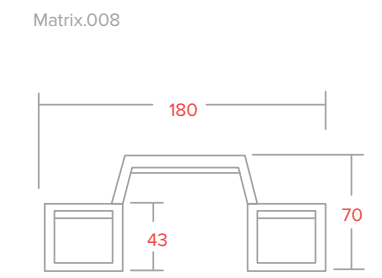
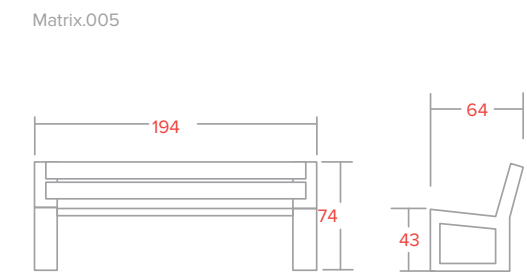
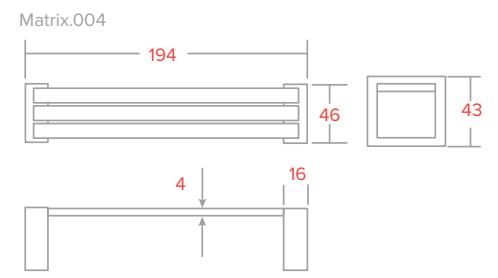

Agora

PURE and SIMPLE lines



Agora planter Useful planting depth : 36 cm



270 X 45 cm



45 X 45 cm



60 X 45 cm



90 X 45 cm



120 X 45 cm



180 X 45 cm



90 X 90 cm

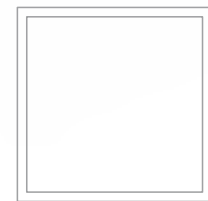

120 X 120 cm





Agora



Agora litter-bin

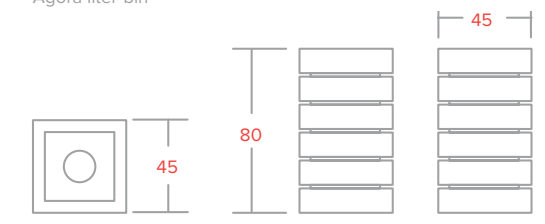

Agora bench

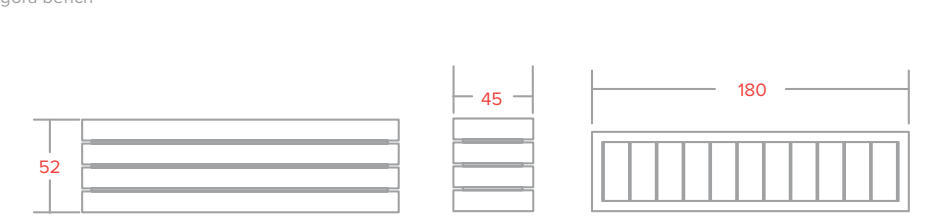



Avenue & Plaza

A touch of **STAINLESS STEEL**

Litter-bin



Plaza planter

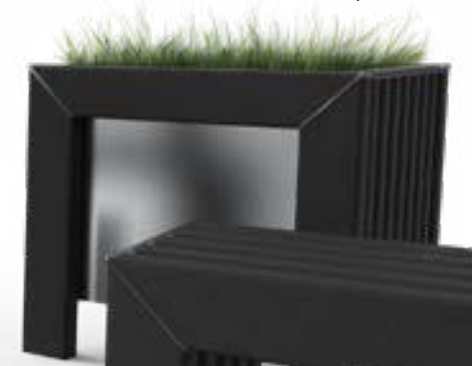

Avenue bench ML



Avenue bench



Avenue bench ML

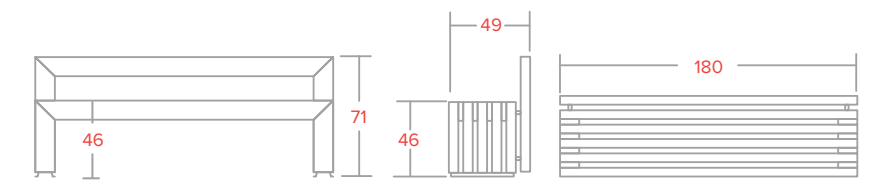

Square

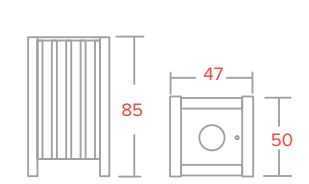

Plaza planter

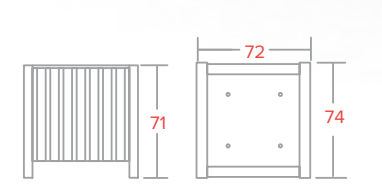

Atlantic

design by CIDES.be

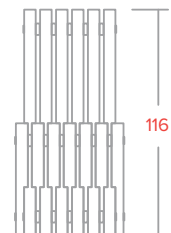
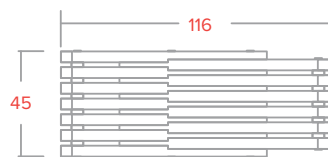
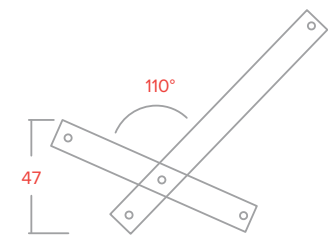

That SEASIDE feeling

The Wave

Coming to rest can look **DYNAMIC** too.

design by CIDES.be

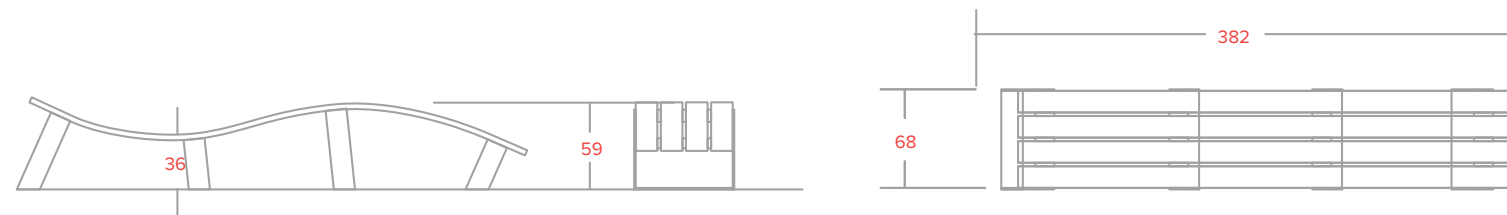

Level X

design by CIDES.be

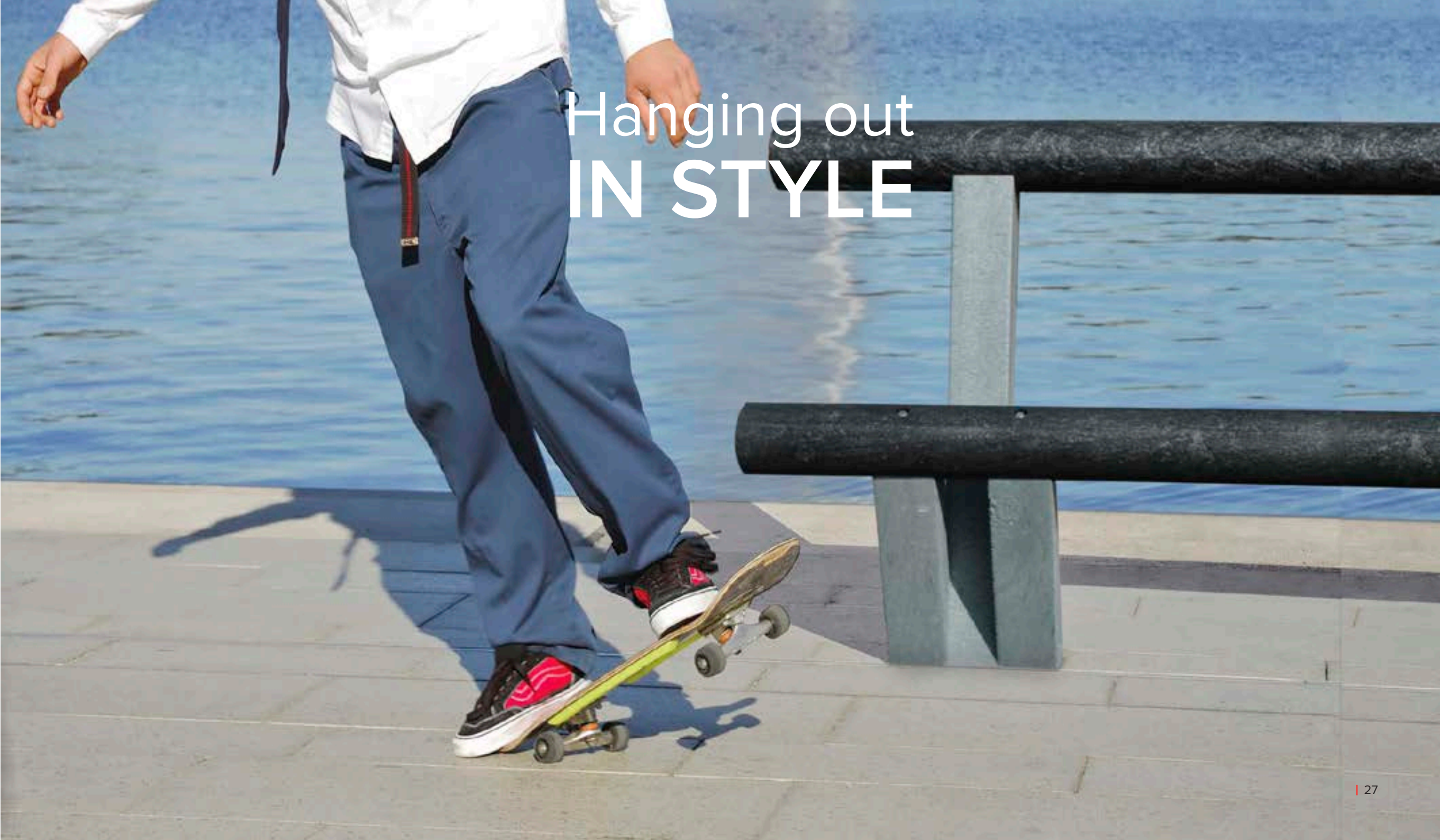
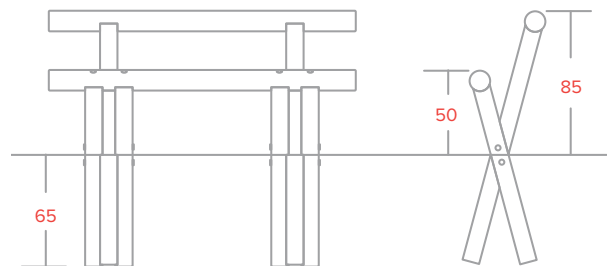

Hanging out
IN STYLE

ONE DESIGN,
endless possibilities!

Canvas

design by CIDES.be

ECODESIGN AWARD

LAUREAAT DESIGNPRIJS 2008

Henry Van De Velde Labels

canvas 360



canvas 180



Canvas 180

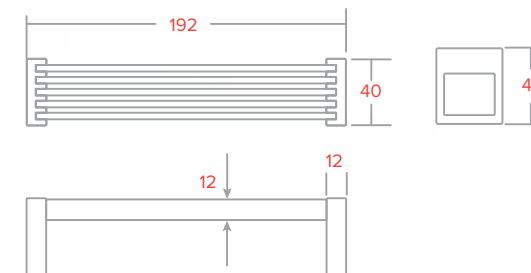

Canvas 360

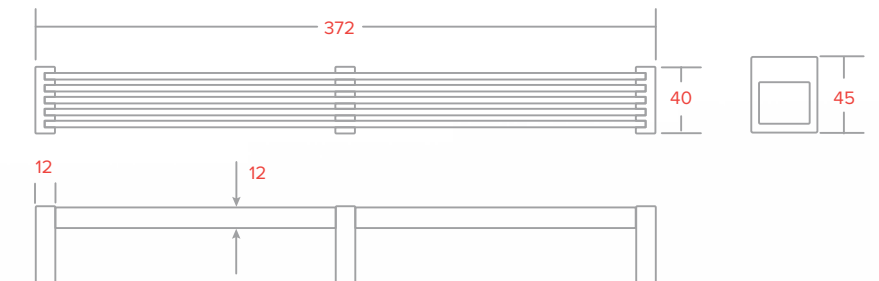



Canvas 30°

CURVES or **LINES**
the choice is yours!

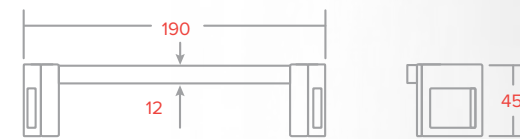
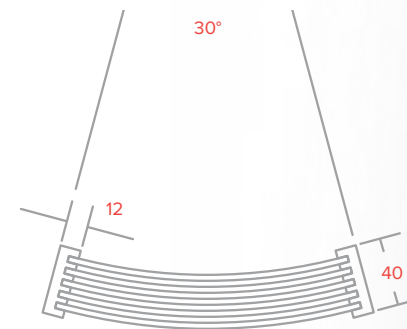

Canvas ML

canvas 180

canvas ML 180

192

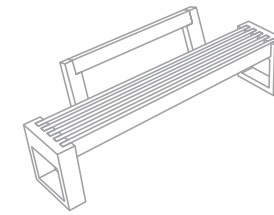
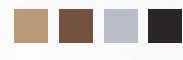

canvas 180 ML

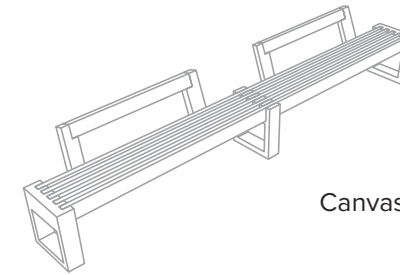

Canvas 360 - 2N

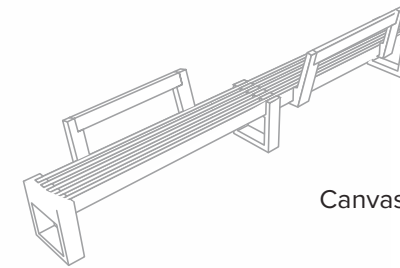

Canvas 360 - 2DL

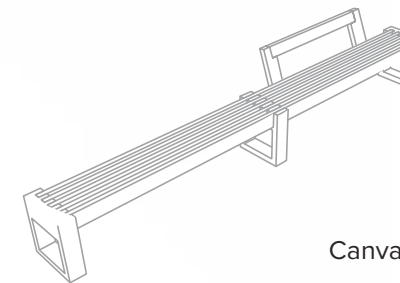

Canvas 360 - 1R



Canvas T



Canvas T

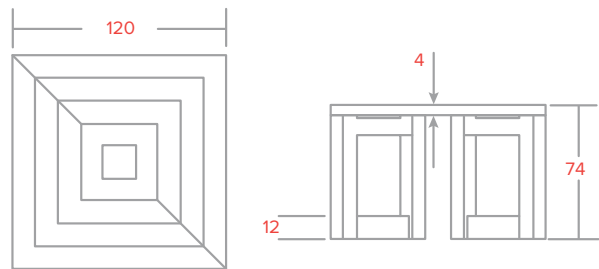

Canvas 120

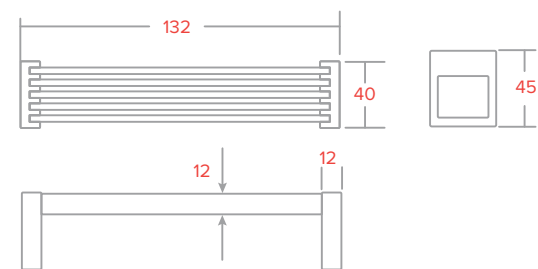

Let's have
A REST

NO NONSENSE” outdoor furniture

2.

PURE collection

Traditional furniture with universal appeal. This is the collection we started our furniture adventure with. A selection of our most popular models unpretentiously good.

NL: Dit is onze eerste collectie straatmeubilair; stuk voor stuk populaire modellen van topkwaliteit. Tijdloos design met een universele uitstraling.

FR: La collection avec laquelle nous avons démarré notre aventure dans le mobilier est plus traditionnelle avec un charme universel.

DE: Traditionelle Möbel mit universellem Charakter. Mit dieser Kollektion haben wir das Abenteuer Möbel begonnen. Eine Auswahl unserer beliebtesten Modelle, unprätentiös und gut.



Bonn

Still standing out in
SIMPLICITY & FUNCTIONALITY



Bonn ML

Bonn ZL

Bonn ML 360 cm

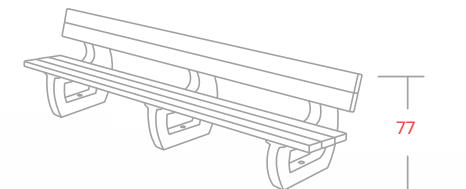
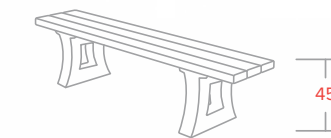
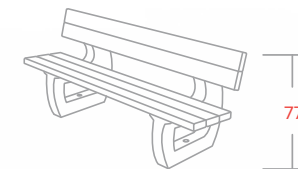

London

A GREEN SOLUTION in the green



London 4 ML

London ML

London ML 360 cm

London ZL

London T

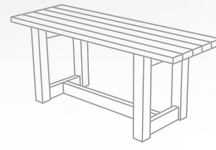
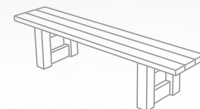
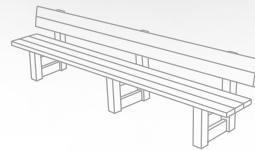
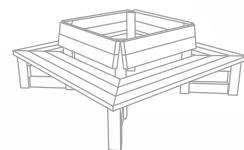



Roma

For PICNIC parties of 12





Paris

■ ■ ■ ■ ■ Focus on **FUNCTION**



Rotterdam

■ ■ ■ ■ ■ Traffic speed
OBSTRUCTION



Jupiter

■ ■ ■ ■ ■ **MATCHES** with
every bench or planter

A photograph of a modern building with a large glass facade and a courtyard with picnic tables. The building has a prominent glass section with a white frame. The courtyard is green with several picnic tables and a row of young trees in the foreground.

Street furniture to suit
EVERYONE ”
in ANY situation

3.

COMFORT collection

This collection consists of favorite designs bearing comfort and practicality in mind.

NL: Deze collectie bestaat uit een aantal van de meest comfortabele en praktische ontwerpen.

FR: La sélection de nos modèles les plus populaires, pratiques et sans prétention.

DE: Diese Kollektion besteht aus beliebten Designs, die alle für Komfort und Zweckmäßigkeit stehen.



“ A great
PICNIC SPOT

Student at the Katholieke Hogeschool Kempen

Oslo

The **ICONIC** picnic table.



Oslo XL

Oslo

Oslo Junior



Oslo

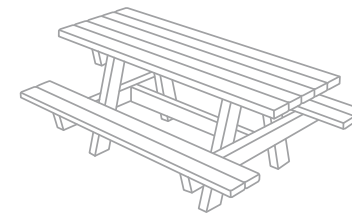

Oslo XL

 **WHEELCHAIR**
accessible

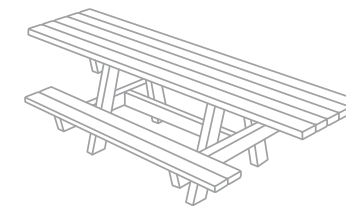

Oslo Junior

 **CHILDRENS**
model

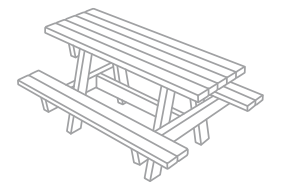

Oslo

The **ICONIC** picnic table.



Oslo Mensa



Oslo Campus



Oslo Mensa  **CLOSED BOARD**
table top

Oslo Campus  **EXTRA wide**
table top

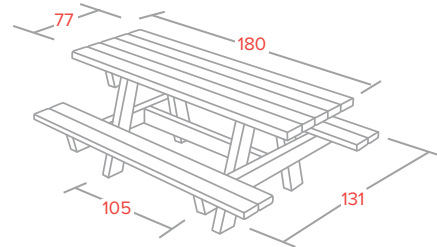
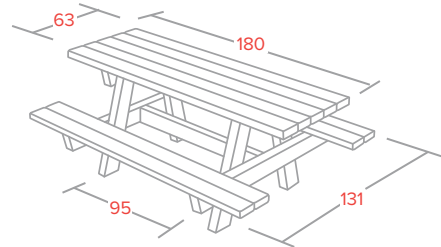



Lyon

It is **EASY** to take a seat



Lyon ZL

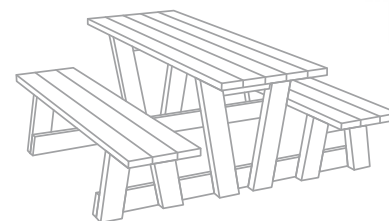

Lyon ML

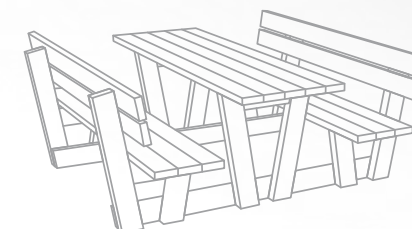

Mercure

UNIVERSAL litter bin

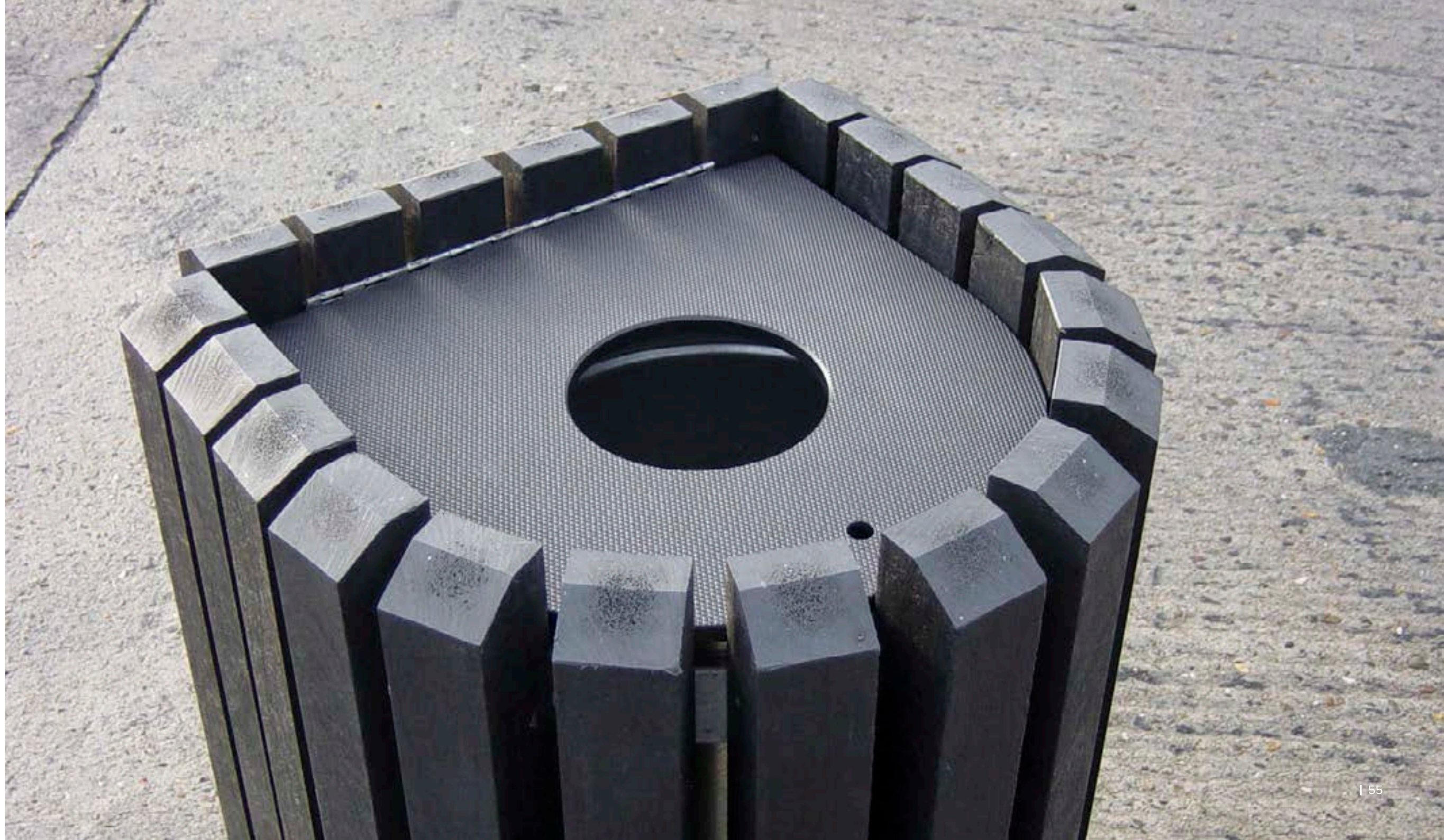



Porto

The mix of **ELEGANCE** and **SIMPLICITY**



Siena

Easily accessible

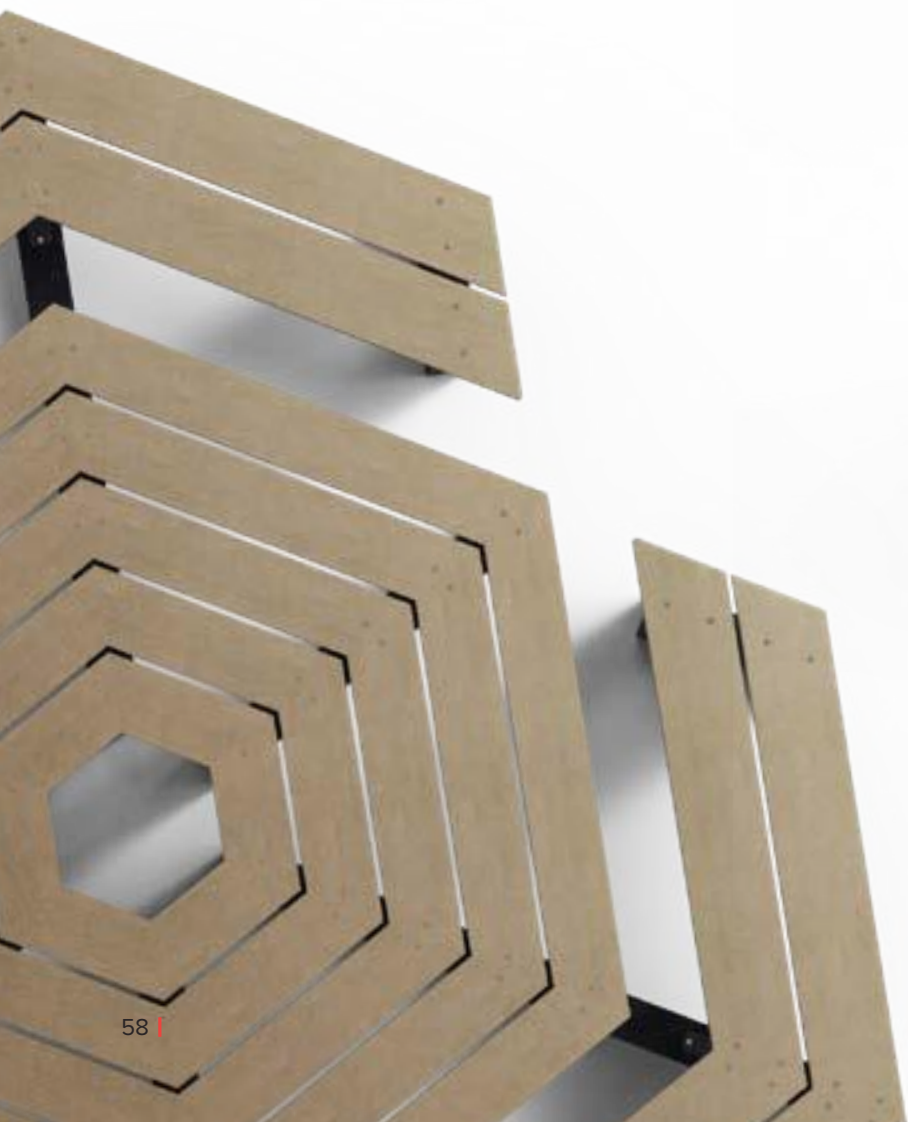

A PLEASANT OASIS

with view on the Zwin plane





Knokke ML

Knokke

In harmony with **NATURE**



Knokke ML

Knokke ML-G

Knokke ZL



Knokke ZL

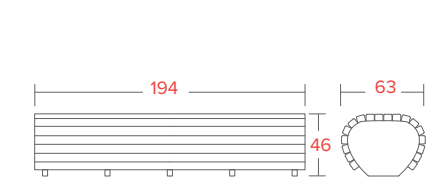

Knokke ML-G

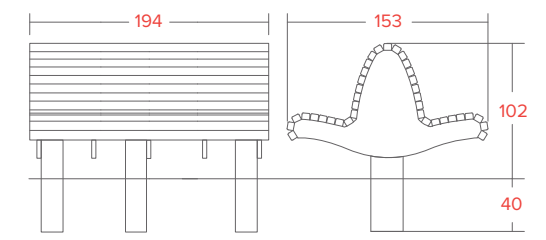

Knokke ML

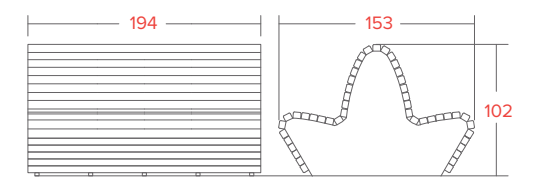



Normandie

Fencing panels for
QUICK and **EASY**
installation

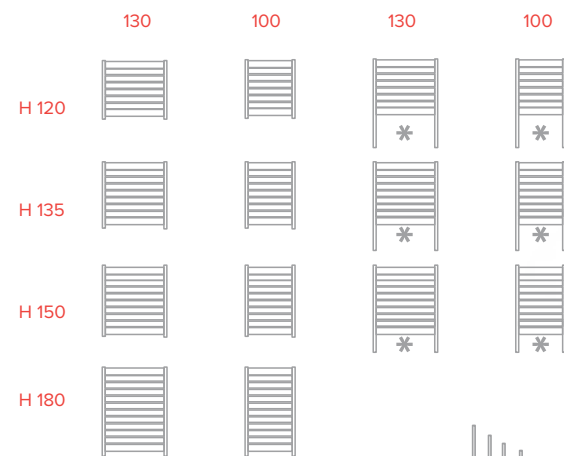
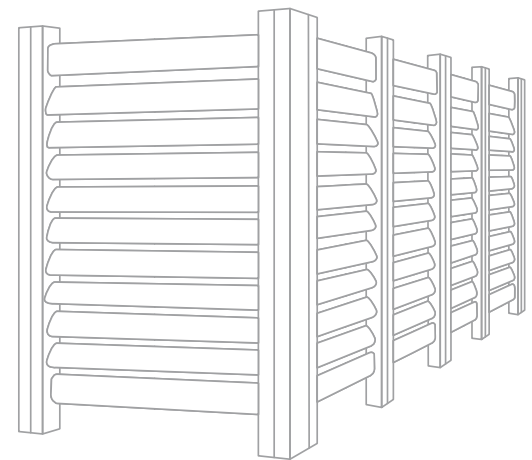

With extended legs
Met verlengde poten
Avec pieds prolongés
Mit verlängerten Füßen



SUSTAINABLE

highway solutions

4.

TRAFFIC

collection

Every bollard installed keeps unwanted traffic away and increases your level of security, on public areas but also on business and private properties.

NL: Antiparkeerpalen verhinderen de doorgang van auto's en verhogen uw veiligheid, zowel op openbare plaatsen als op bedrijfs- en privéterreinen.

FR: Chaque borne installée tient à distance la circulation indésirable et augmente votre niveau de sécurité, et ce, dans les espaces publics, mais également sur des propriétés commerciales et privées.

DE: Jeder Poller hält ungewünschten Verkehr fern und erhöht Ihre Sicherheit, sowohl im öffentlichen Raum als auch auf Firmengeländen und Privatgrundstücken.

Square bollard with diamond head & REFLECTIVE STRIPS



Square bollard

REMOVABLE or not removable

Removable bollards are perfect for roadways and parking lots that periodically close.

?

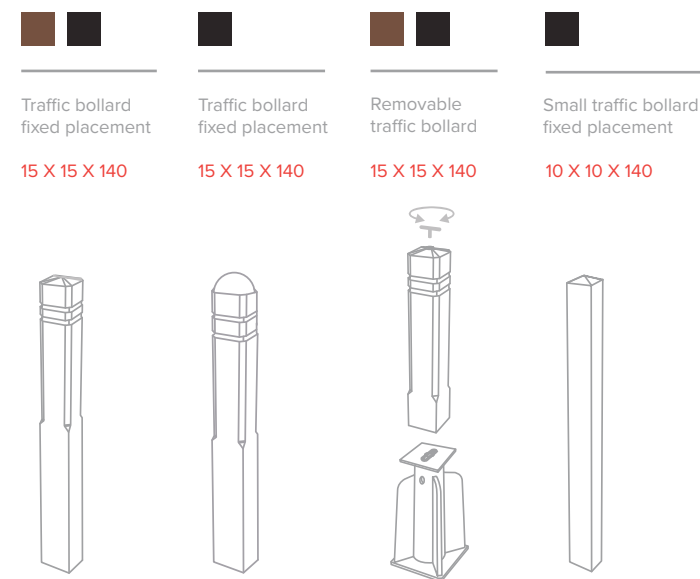

Octagonal bollard

Round head &
REFLECTIVE STRIP



Round bollard

Domed top &
REFLECTIVE STRIP

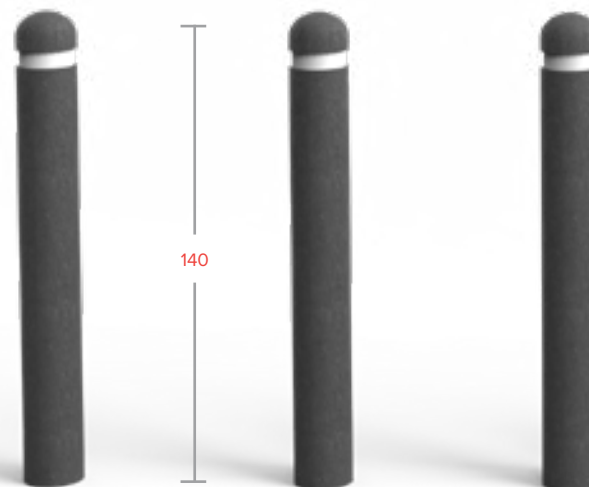

■ Ø 13,5 X 140 12kg



Roadside post

marking the ROAD VERGE

2 cut-aways for reflectors
or information signs

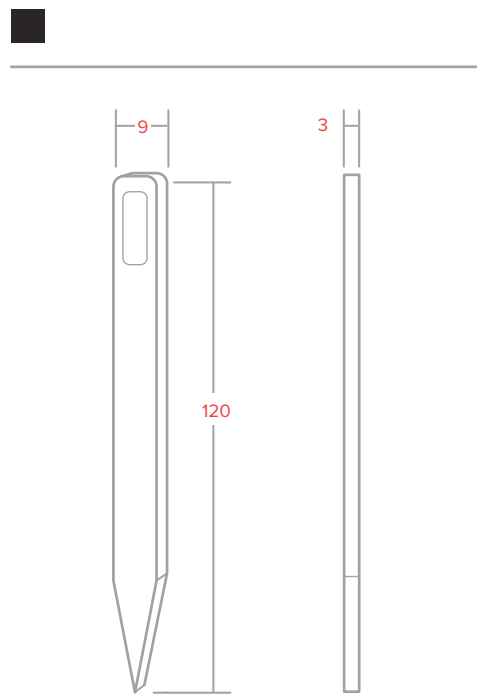

Trail post

marking HIKING routes

4 x 5 cut-aways

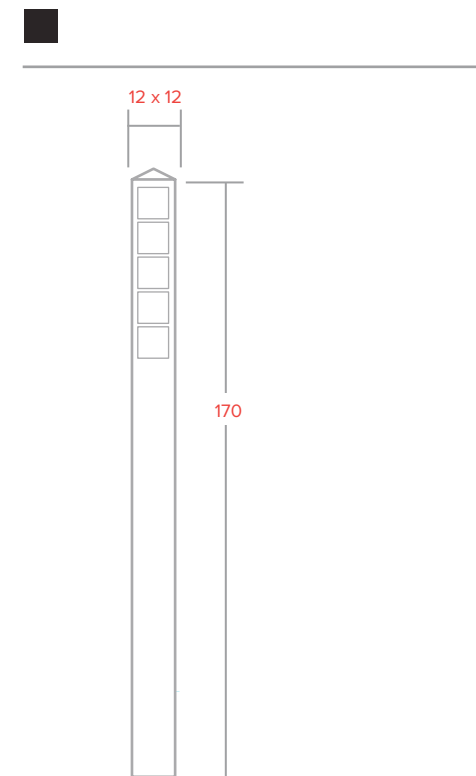

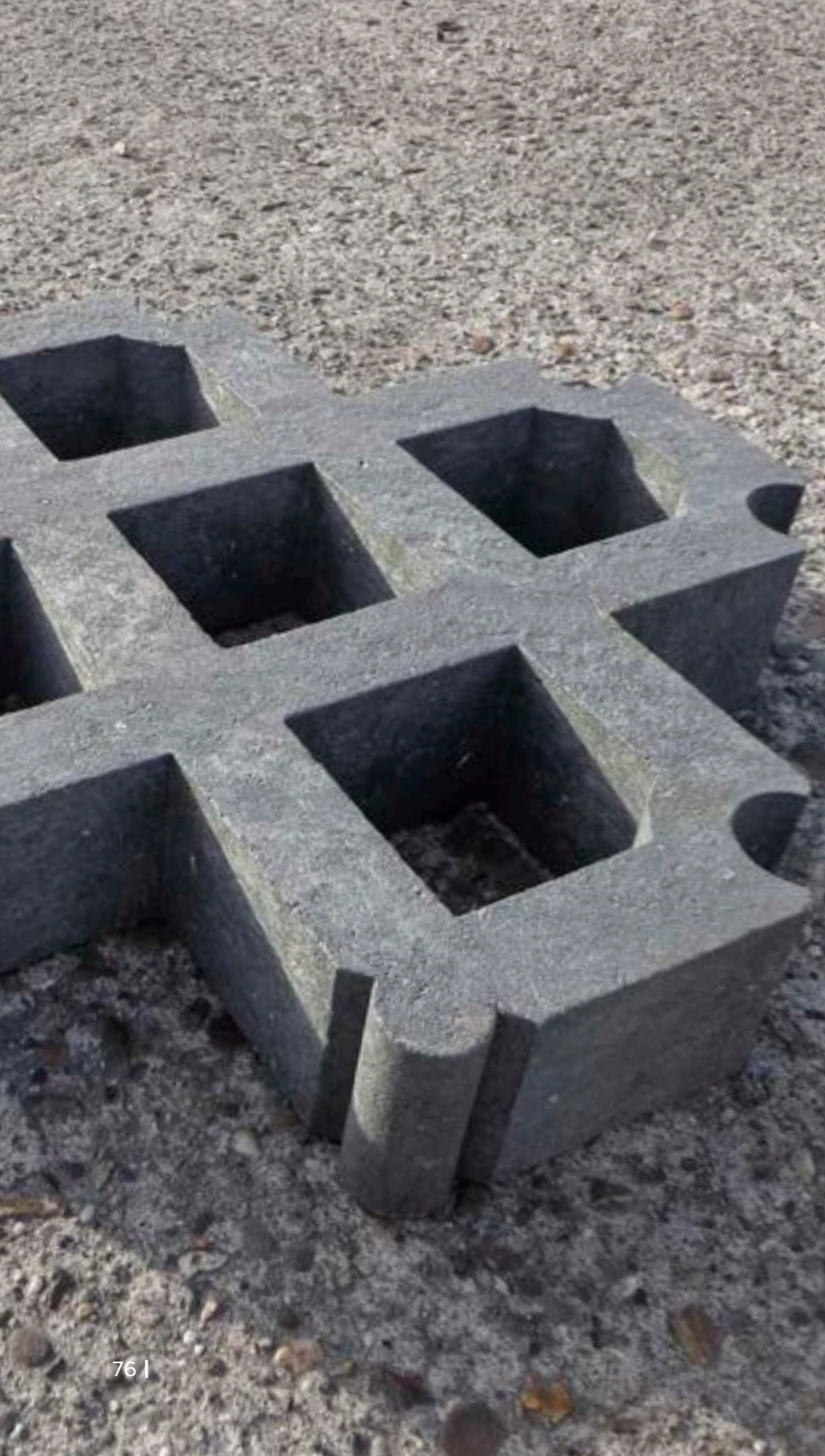

Grass tiles

Permeable paving today has become a must.



■ raw finish

10 X 60 X 40 12 kg



Thanks to their light weight they can easily be placed by one person.

Ground fixing sockets

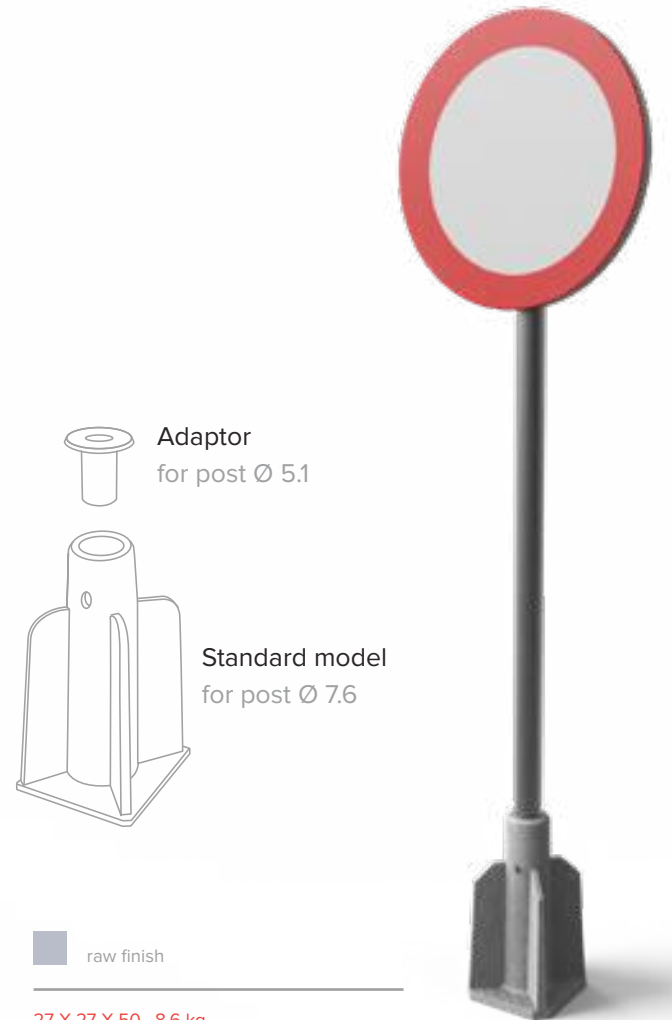

Adaptor
for post Ø 5.1

Standard model
for post Ø 7.6

■ raw finish

27 X 27 X 50 8,6 kg

Discover our wide product range

GOVA[®]
PLAST

Switch to Quality

| Boards
| Sheets

GOVA[®]home⁺
PLAST

| GOVADECK[®]
| GOVAWALL[®]

GOVA[®]horse
PLAST

| Stable boards
| Rubber tiles

GOVA[®]play
PLAST

| Play Objects
| Play Furniture
| Fall protection

GOVA[®]technic
PLAST

| Retaining walls

Govaerts Recycling nv
Industriepark Kolmen
Kolmenstraat 1324
B-3570 Alken

info@govaplast.com
www.govaplast.com



V. 200920

